



SUMP BOTTLES



Trico sump bottles are used as collection chambers on bearing housings and other oil sump applications. They collect water and contaminants, and have a drain plug for easy inspection and removal of fluids.

FEATURES

- Easy open/close drain valve
- Plastic reservoirs have reinforcing ribs for long life and impact resistance
- Copper brazing of all steel connections provides long life and leak proof design
- Zinc plating resists corrosion

SPECIFICATIONS

Max. Operating Temp.	165°F Continuous
Reservoir	Butyrate Plastic
Gasket	Buna-N
Materials	Steel and Brass
Finish	Bright Zinc Plated

SELECTION CHART

Model No.	Capacity	Connection (NPT)	Dimensions (in.)	
			A	B
31321	2 oz.	1/8	1-15/16	2-1/16
31341	4 oz.	1/8	2-5/16	2-7/8
31342	4 oz.	1/4	2-5/16	2-7/8
31382	8 oz.	1/4	2-5/8	4

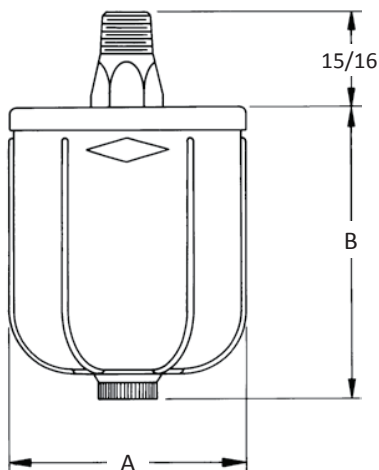

HELPFUL TIP:

Oil should be clear and bright in sump bottles. If water or sediment is observed, remove immediately and investigate source. Up to 70% of equipment fails prematurely due to contamination in lubricants.