

Adams

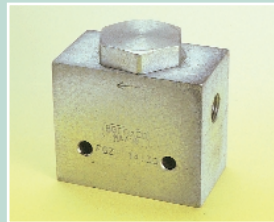
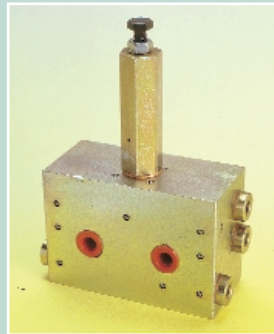
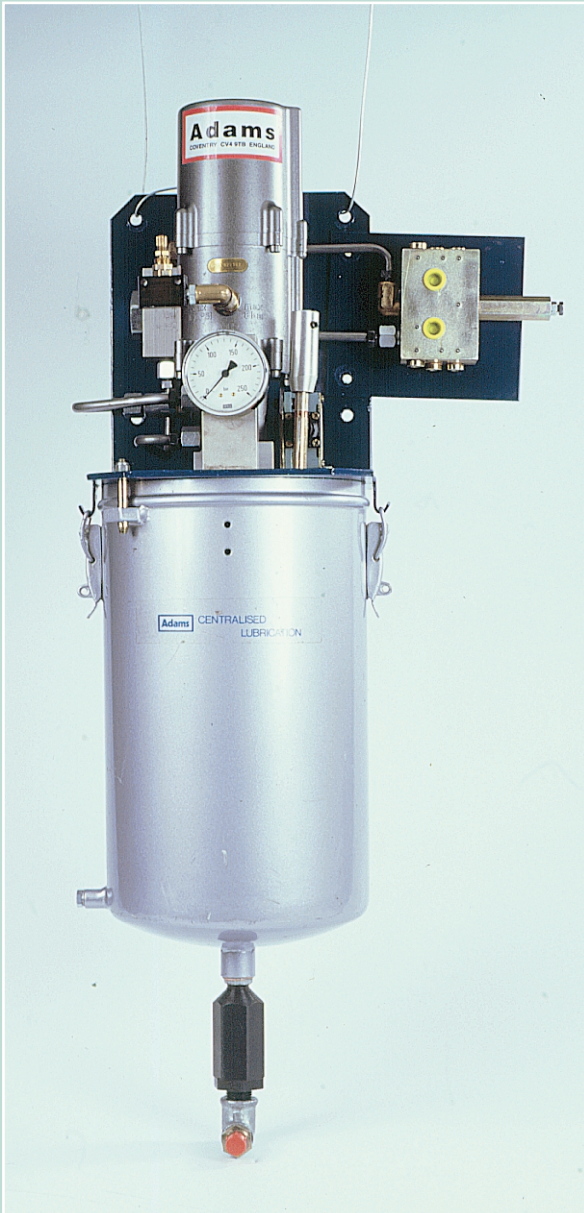

□ Dual Line

Dual-line lubrication systems are normally used to provide measured quantities of grease to heavy duty plant and machinery. The installation can use smaller bore tubing to cover longer distances than is the case with single line systems. Grease up to Grade 3 (NLGI) may be used.

Description

A Dual-Line lubrication system is composed of a central pump which supplies a series of metering distributors through two separate circuits: one of which acts as the lubrication supply line, while the second line is relieved of pressure via the line reversing valve. The purpose of this valve, which is situated between the pump and the distributors, is to direct the lubricant under pressure first to Line One then to Line Two, ensuring all points are served. The line reversing valve, which is also referred to as an inverter, can be mechanical, hydraulic or electrically operated.

Each piston in the metering distributor is adjustable for discharge stroke, and an indicator rod gives visual evidence of correct volumes to each point. The hydraulic simplicity of a Dual-Line system, together with high operating pressures, makes it very suitable for heavy duty applications.

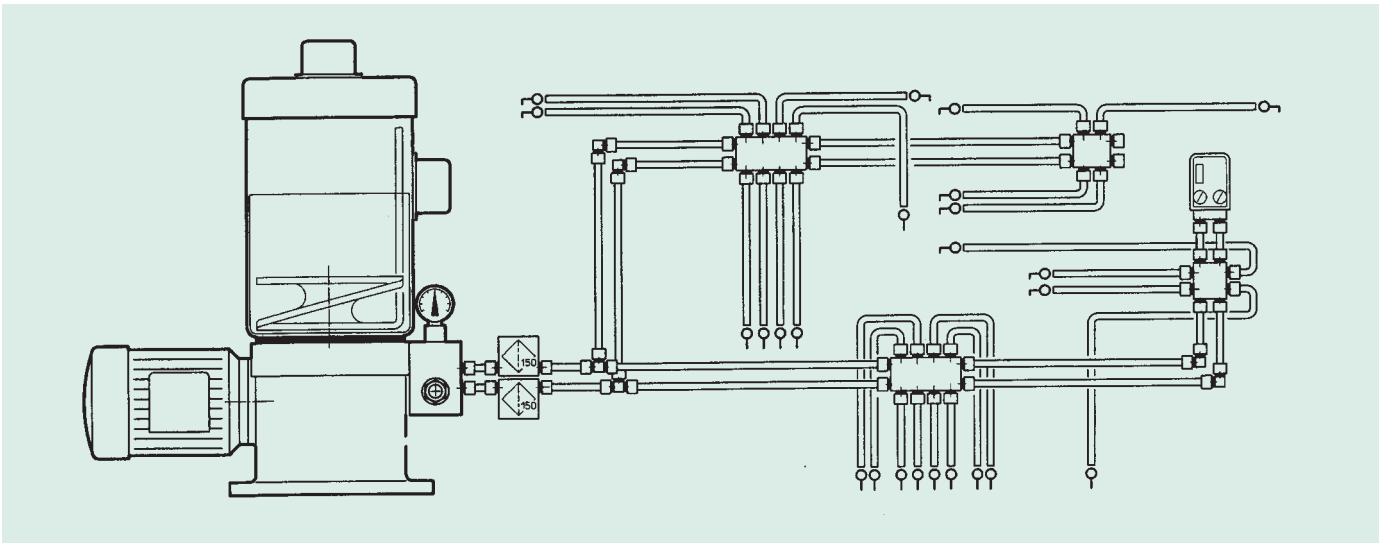

Typical Dual-Line System, showing pump, Inverter and Distributors.
Optional Timer Control to automate system

Operation

As pressure builds up in Line 1 (L1) spool valve (S) moves down to allow pressure above piston (D). High pressure then displaces lubricant below piston (D) via groove in spool (S) and out of metered port (M2) - at this stage Line 2 is free to dissipate pressure back to reservoir.

When pressure in Line 1 reaches pre-set limit inversion takes place at Line Reversing Valve which causes lubricant to be discharged from M1. Stroke can be adjusted at point (R).

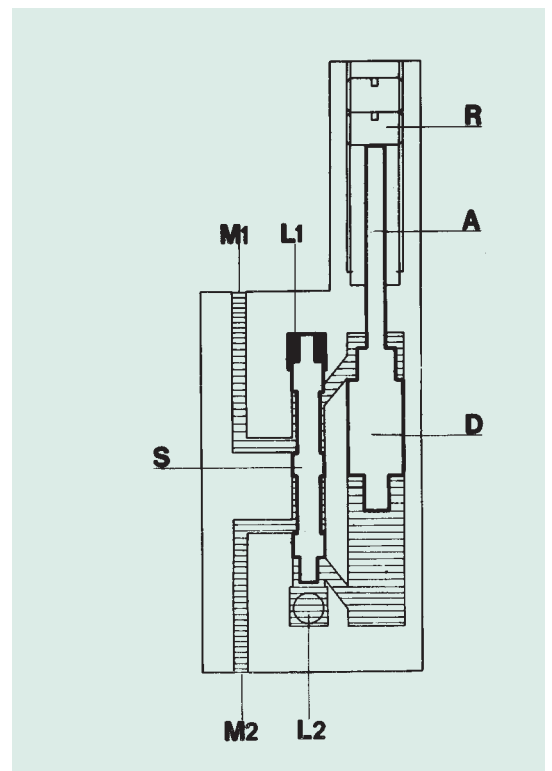

Section Through Metering Distributor showing Lubricant passageways and discharge piston 'D' and directional spool valve 'S'

Motorized Pump - Type ZBK

Part No.	Res Cap'y.	A	B	C	D	E	F	G
LV 61285	30 kg	809	550	840	330	500	600	1/2 BSP
LV 61294	40 kg	929						
LV 61303	100 kg	1018			500			

ZBK 12M Range
 Operating Pressure - up to 300 bar
 Output - up to 10 kg per hour
 Lubricants - up to Grade 3 Grease (NLGI)
 Reservoir Sizes: 30, 40 & 100 kg
 Voltage - 400V 50Hz 3 Phase

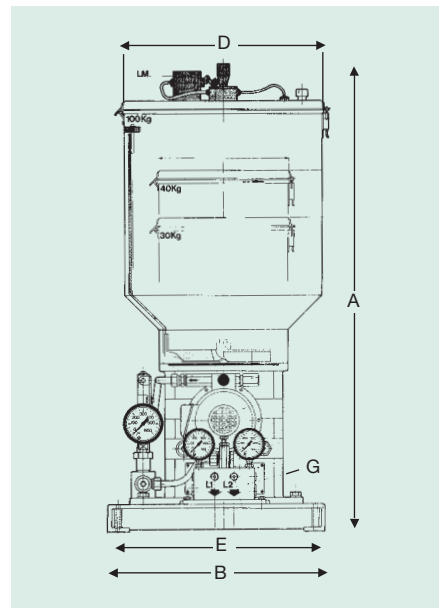
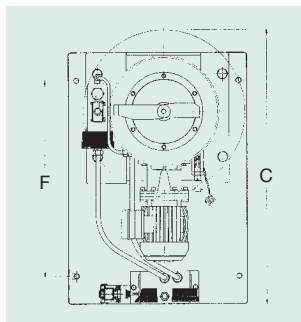

Manual Pump - Type ZMK

Part No.	Res. Cap'y.	A	B	C	D	E	F	G
LV 61039	2 kg	295	150	170	132	94	63	3/8 BSP
LV 61040	5 kg	445						

Operating Pressure - 50 to 200 bar
 Output - 3.5 cc/stroke
 Lubricants - up to Grade 3 Grease (NLGI)
 Reservoir Sizes: 2 & 5 kg

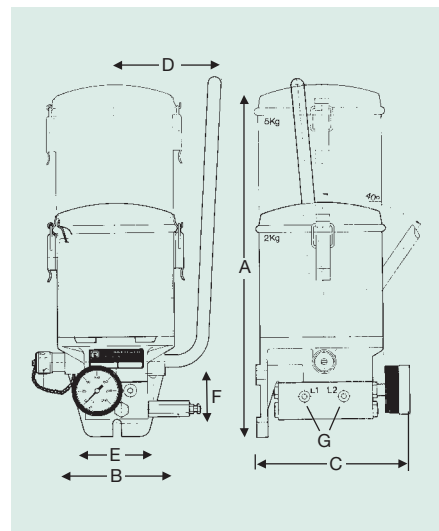

Air Operated Pump - Type PPK

Part No.	Res. Cap'y.	A	B	C	D	E	F	G
LV 60398	5kg	675	210	237	440	170	160	1/4 BSP

Air Pressure - 4.5 to 7 bar
 Operating Pressure - 50 to 180 bar
 Output - Between 200 and 600 /gram per minute
 Lubricants - up to Grade 2 Grease (NLGI)
 Reservoir Size: 5 kg

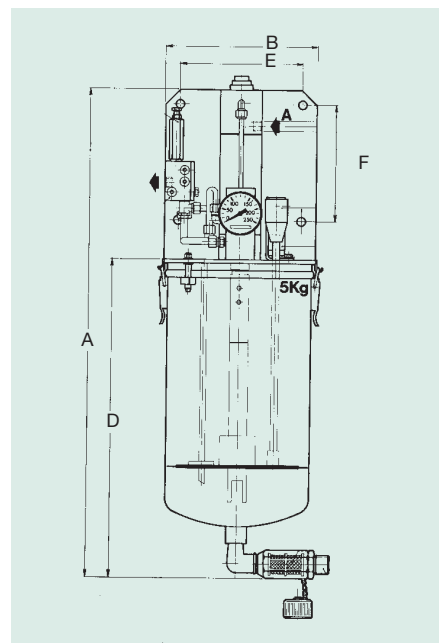
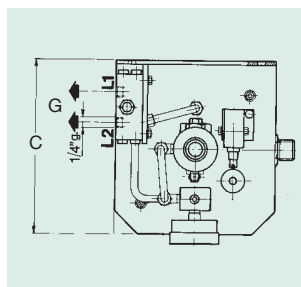

Note: All Pumps have built-in
 Line-reversing Valves

Metering Distributors - For Oil or Grease

Type BM - Output per single outlet - 0.25 to 3 ccm,
adjustable Max Pressure 300 bar

Part No.	No. of Outlets	A	B	C
LV 51857	2	128	57	46
LV 51859	4		80	
LV 51863	6		103	
LV 51869	8		126	

Lubricant Inlets
Threaded 3/8 BSP

Outlet Tube Nut LV 90482
Outlet Sleeve LV 90682
For 8mm \varnothing Tube

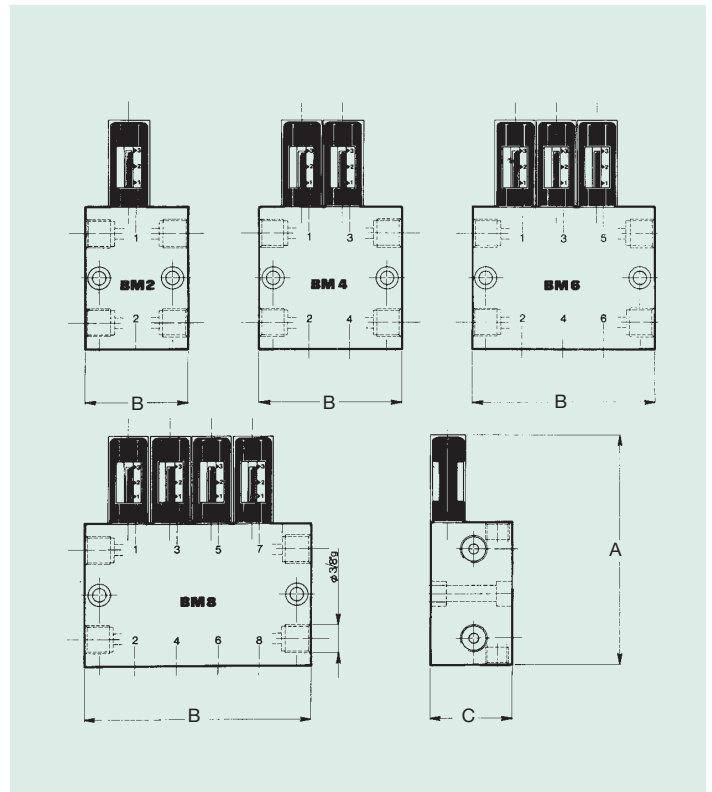

Type BG - Output per single outlet - 1.5 to 13 ccm,
adjustable Max Pressure 300 bar

Part No.	No. of Outlets	A	B	C
LV 51877	2	214	70	65
LV 51879	4		106	
LV 51883	6		144	
LV 51889	8		183	

Lubricant Inlets
Threaded 3/8 BSP

Outlet Tube Nut LV 90411
Outlet Sleeve LV 90511
For 10mm \varnothing Tube

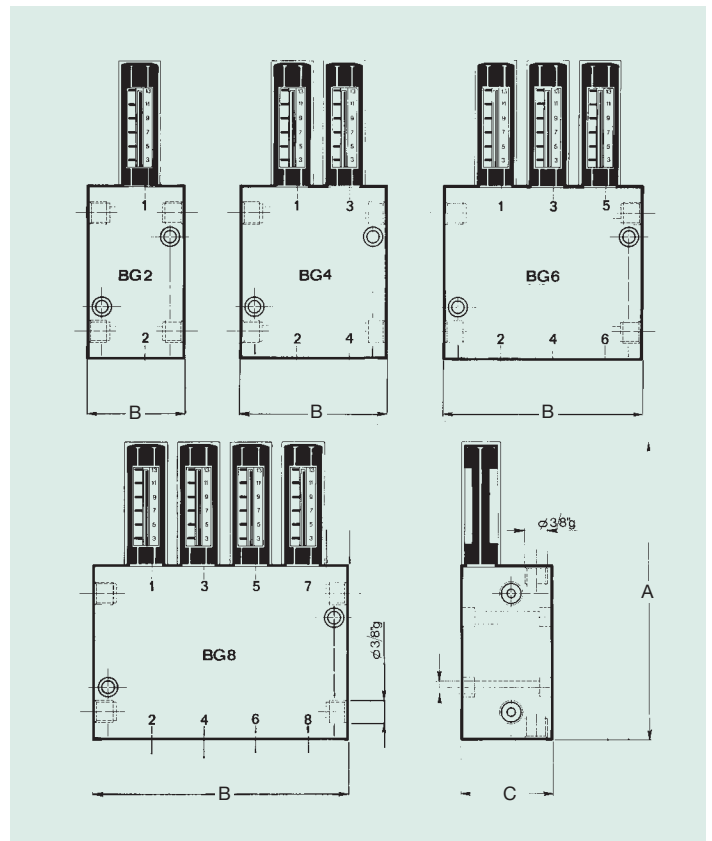

Accessories for Dual-line Systems

Line-reversing - Valves (inverters)

YKS Type (LV 61364)

Max Pressure: 150-300 bar

Capacity: 15-25 kg per hour

YMS Type (LV 61372)

Max Pressure: 150-350 bar

Capacity: 60-80 kg per hour

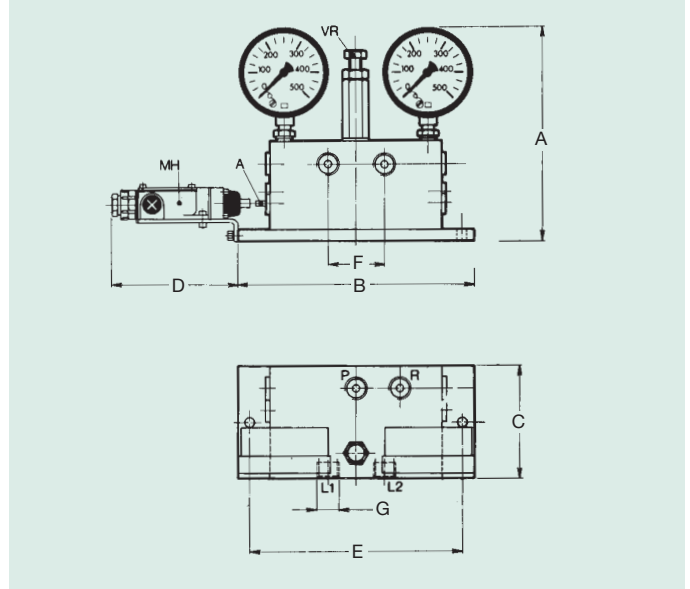
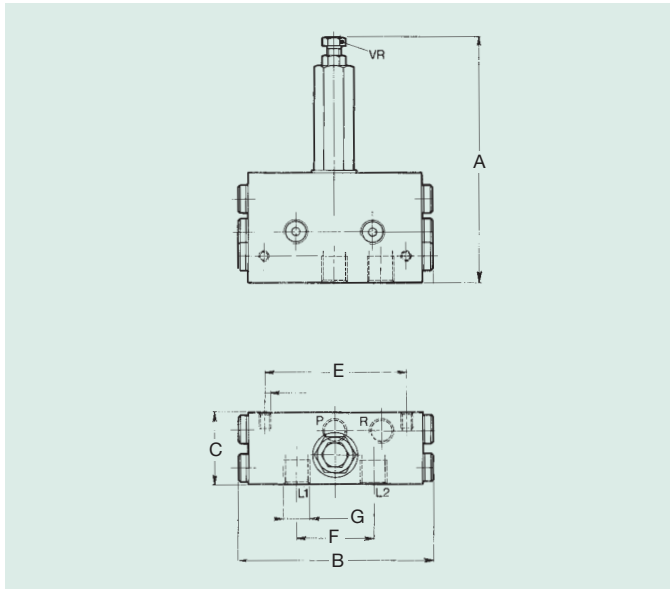

Part No.	A	B	C	D	E	F	G
LV 61364	125	96	35	-	70	38	1/4 BSP
LV 61372	185	210	100	110	190	50	1/2 BSP

'End-of-Line' Pressure Switch Assembly

LV 10438 with 1 switch and 1 pressure gauge complete with Air Bleed Screw. For use with Control Timer to monitor system LV 96105 (with 2 separate pressure switches)

Part No.	A	B	C	Operating Pressure
LV 96102	226	146	3/8 BSP	20-400 bar
LV 96105	226	146	3/8 BSP	450 bar

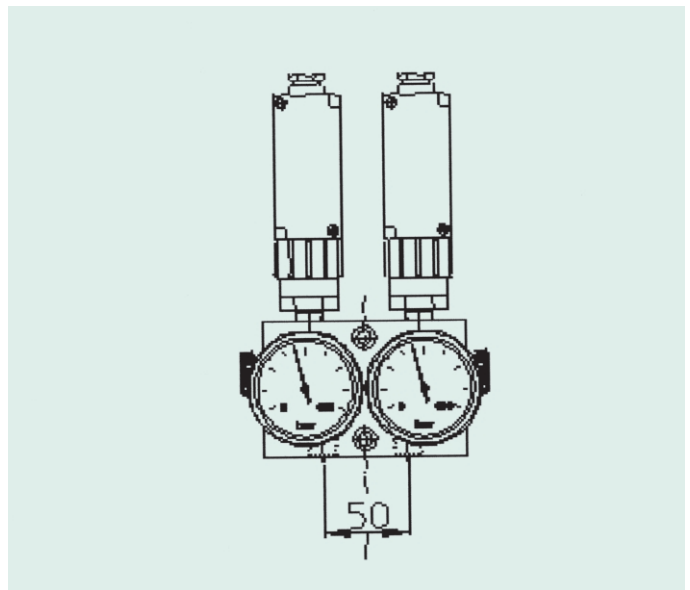

Grease Filters

With washable wire mesh basket

Filtration 300 micron

Pressure 350 bar

For maximum protection of system use 1 filter for each main line

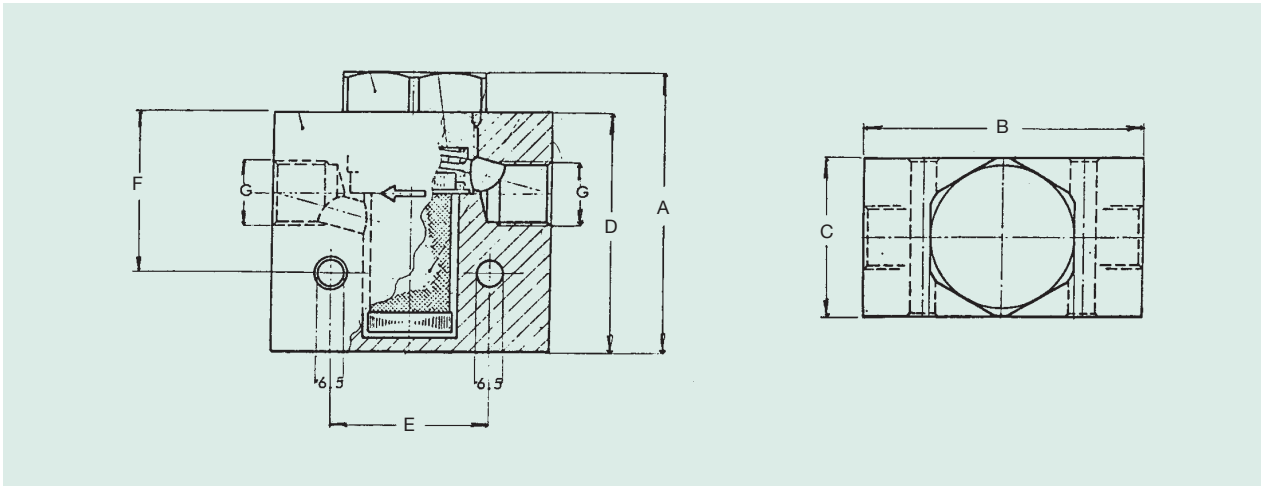

Part No.	A	B	C	D	E	F	G
LV 95714	70	70	40	60	40	40	1/4 BSP
LV 95717							3/8 BSP
LV 95718							1/2 BSP

Fittings

All fittings used on dual-line systems should be of the high pressure type i.e. they must withstand working pressures of up to 300 bar

Timers

A range of control timers and system programmers are available. These are shown on page 20.